

When repairing a Multi-Max composite door, the repair person can choose the best of four options:

- 1- REPLACE CORE – If the core is crushed or delaminated, but the skin is in good condition, a section of core can be replaced. Cut out the damaged balsa wood from between the fiberglass skins. Preferably cut out a uniform rectangular area, keeping the fiberglass skins intact. Cut a piece of wood to the exact thickness of undamaged balsa (approx. 9/16, but may vary). Coat the pocket and wood with fiberglass resin, insert the wood piece and clamp. After curing, match drill holes for hardware, and apply paint or resin to the inside hole surfaces.
- 2- SPLICE – When the skin is damaged, the entire affected area must be replaced. Cut off the damaged area, typically full width and 4”-6” in height. Replace this with new panel material of identical width (could be recut from a discarded panel if there is an undamaged portion). Connect the splice together using 11 GA steel plates both sides. Bond in place with Ashland Pliogrip (7779/300), and fasten with 3/8 dia bolts spaced 7/8”-1” away from the cut edge. There should be at least five fasteners on each side of the splice (10 total), *including* other hardware that spans across the splice.

Splice locations for panels 2 and 3:

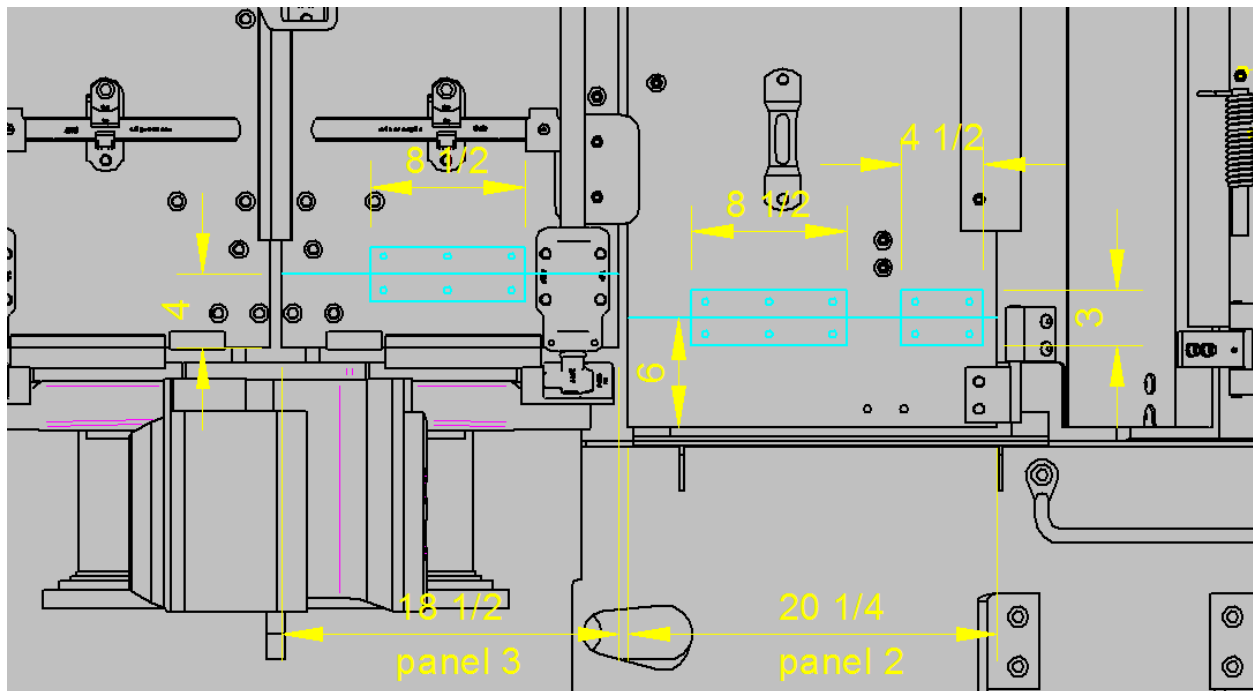

- 3- APPLY COVER PLATE – This only applies to the inboard corner of panel 2, and only if the damage does not extend past existing hardware. Fabricate a tight-fitting U-shaped cover that is larger than the damaged area. Bond in place with Ashland Pliogrip (7779/300), and fasten with four 3/8 dia bolts with lock nuts.

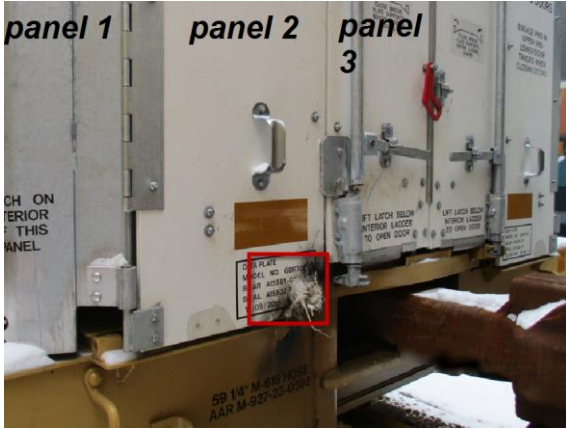

Typical repair location



U-shaped cover plate

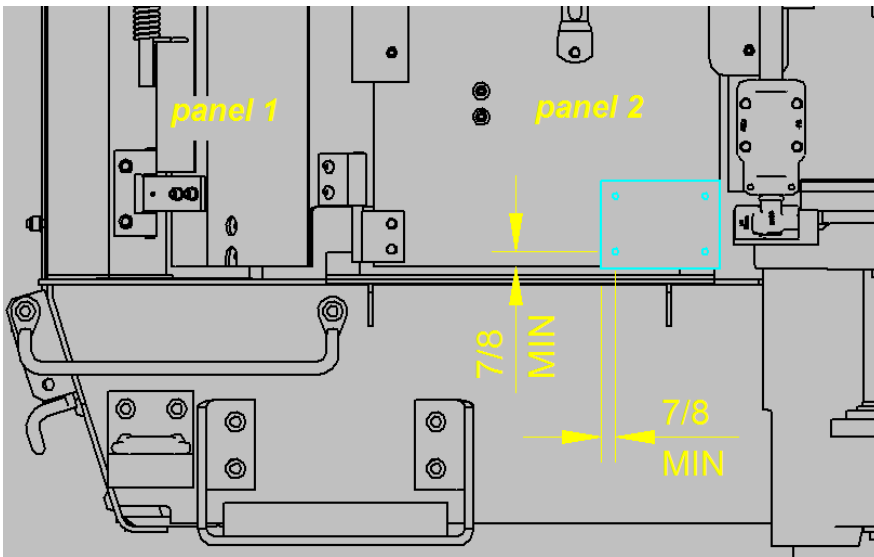

Typical repair on panel 2

REPLACE – order new panel from Greenbrier PDX parts: Traci.johnston@gbrx.com or jill.ozuna@gbrx.com